

城镇污水处理厂污泥处理处置技术指南

.....	1
.....	2
.....	4
.....	4
.....	5
.....	7
.....	13
.....	13
.....	15
.....	23
.....	30
.....	35
.....	37
.....	39
.....	39
.....	44
.....	58
.....	60
.....	63
.....	63
.....	65
.....	68

1

2

3

4

“ ”

5

1

m³

80%

5~10 t

2

2.1

97 ~98

99.2 ~99.8

94 ~96

80%

m/kg

20~60× 10¹² m/kg

100~300× 10¹² m/kg

40~80× 10¹² m/kg

1× 10¹¹ m/kg

1× 10¹³ m/kg

2.2

20~60 20~60

2-2

2-2

	/ MJ/kg
	15~18
	8~12
	5~7

2006 140

2-3

2-3 2006 140 mg/kg

	Cd	Cu	Pb	Zn	Cr	Ni	Hg	As
	2.01	219	72.3	1058	93.1	48.7	2.13	20.2
	999	9592	1022	30098	6365	6206	17.5	269
	0.04	51	3.6	217	20	16.4	0.04	0.78

2.3

2-4

2-4

	10^5 /g	10^5 /g	10 /g	
	471.7	158.0	23.3	78.3%
	738.0	12.1	17.0	67.8%
	38.3	1.2	13.9	60%

1

90

220 t 120 t 85 t

40% 60%

60%

2009

1992

280

~~REVISIONS~~

3

5

1

1.1

7

GB/T24600

GB/T

23486

CJ/T 309

1.3

GB/T 23485

2

2.1

2.2

3

kg

IPCC

3-2

3-2

+			
+			
+			
+			
+			

1

94 ~96

80

2

3

3.1

~ â Ã Ã ´ Ê ½ % òK-a- 'i ä\0æ]Ó€“• EÐ 3À• ‡ â â
‡ g â 8 8 [É - â e!

95 ~99.5

75 ~80

97

65 ~75

95

~99.5

75 ~80

4

55 ~65

78 ~85

5

1

1

2

3

GB18918

2

3

3.1

1

2.0~4.0 kg/m³·d

35 ±2

35 ~45

20d

0.75~1.10 N m³/kgVSS

2

55 ±2

35%~45%

10~15d

3.2

4-1

4-2

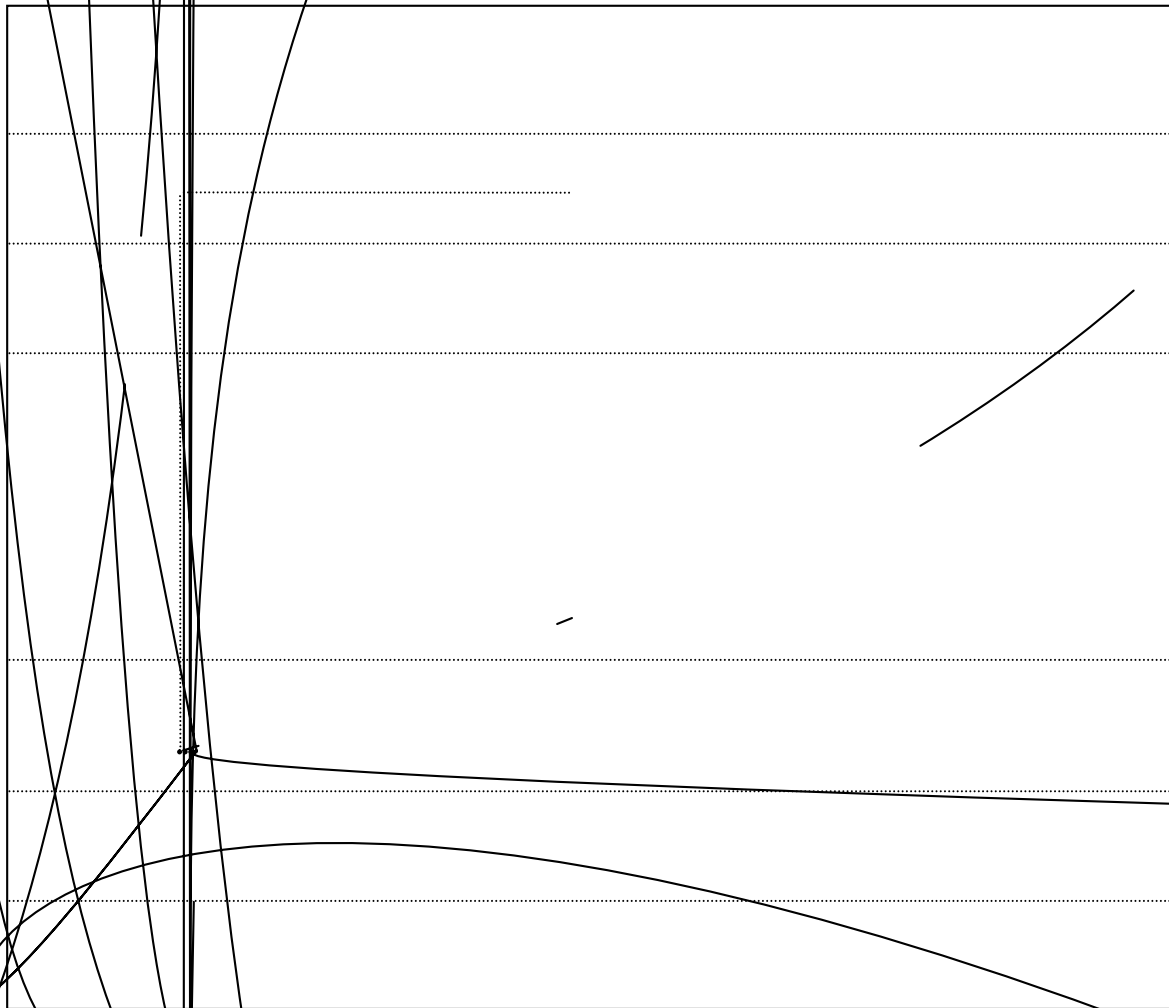

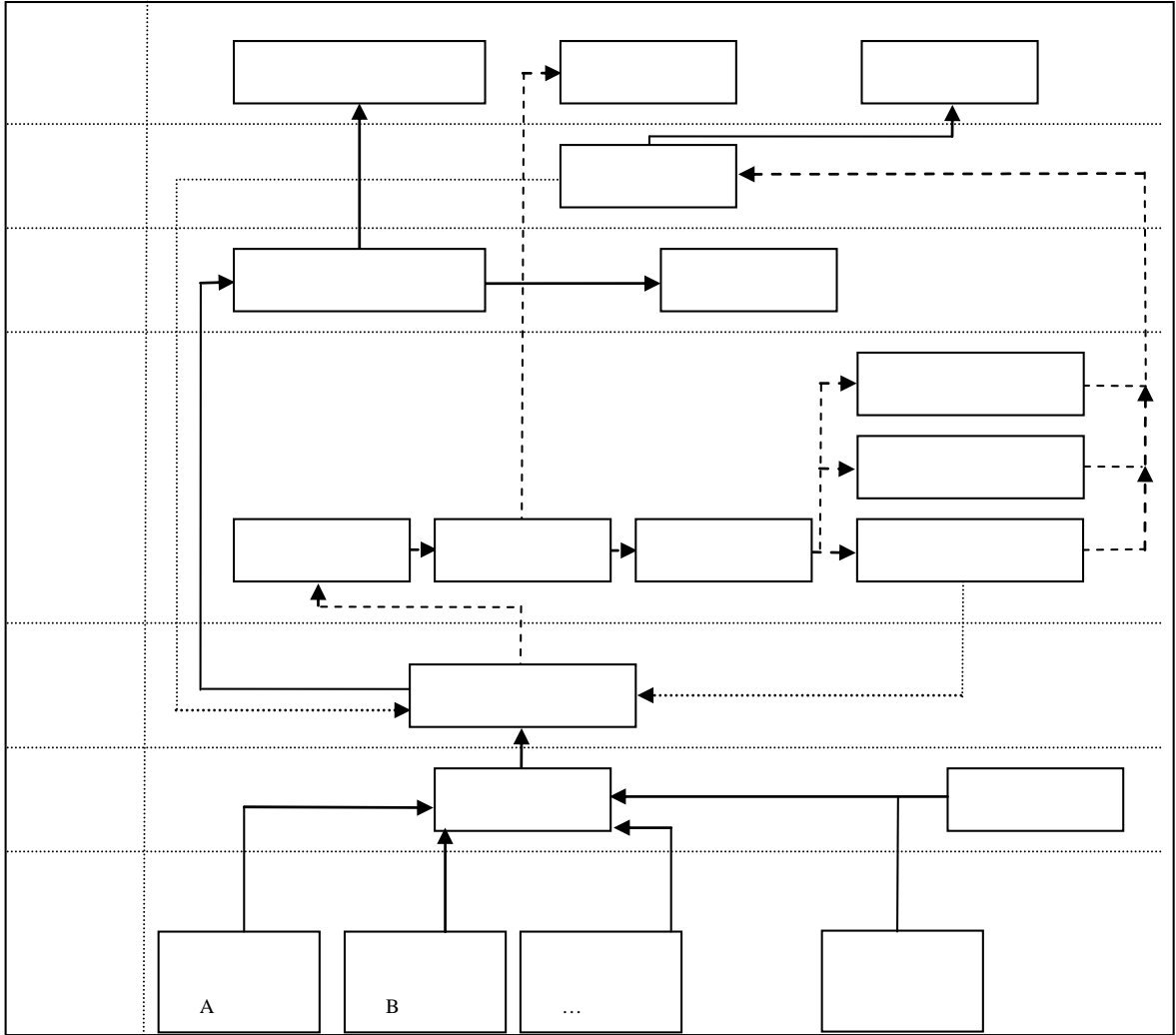

15%-20%

155 ~170

6

bar

4-3

§O(QIO/QBü"R"...

301940f3TCH0 1 7.9856.7 7.985170402 493.7 Tc <04210b7(40 1 Tf 12 0 0 12 56.7 755

NaOH Na₂CO₃
H₂S

3

60%~70%

90%~95%

90%~95%

4.3

90%~95%

Nm³

1.5~2.2 kWh

1

40%~50%

5

5.1

1

10%

2~3

2

24h

7

GB 50058

8

9

GB 50016

GB 50160

6

6.1

300~2000 mg/L

70~200 mg/L

SO₂ NO_x

7

20~40 /t 80%

60~120 /t 80%

0.05~0.10 /t

1

55

2

3

3

1~2 m

3~5 m

5°

2~3 m

4

3.3

1 —

40~50 m³/h

2 —

4.5~5.0 m/min

1.5~2.0 m

3

—

250~300 m³/h

5 m

2 m

1.5 m/min

4

4.5~5.0 m/min

5

6

NH₃ H₂S

NH₃

H₂S

7

3.4

CO₂

1.5~2.5 m

4~7 m

4

C/N

20 mm

55%~60%

35%

C/N

20:1~30:1

pH

6.0~8.0

C/N

4.2

1

2

5%

3.0 m

2 m

C/N

3

5%

55

6d

7d

4-2

4-2

	95% 0.01
	0.2 O ₂ % /min ~0.3 O ₂ % /min
	45%
	60%

4.3

45

30~50d

4-3

4-3

	0.1 O ₂ % /min
	45%
	80%

5

1

H₂S NH₃

CO₂ CO NO_x

H₂S NH₃

GBZ1

GBZ2

GB 14554

2

12h

30d

6

25~45 / t

80% · d

120~160 / t

80%

150~200 m²/t 80%

1

2

3

3.1

4-5

4-5

3.2

1

2

1

40 s1 Tf30 0 TD()TjT Tf1 005 0810381036708f309e0603e2

, @ € d } d e

65

<10%

15%~40%

15%

3~5 mm

1000 kg/h

30 t/d

80%

5000 kg/h

150 t/d

80%

3

<80

<10%

150 ~220

10 mm

8000 kg/h

240 t/d

80%

4

105

100

<10%

200 ~300

30

1000~7500 kg/h

30~225

t/d

80%

5

100 ~40

<5%

250 ~300

30%~40%

1~5 mm

3000~10000 kg/h

90~300 t/d

80%

30~150 m

400 ~500

70 ~90

70

20~120 m

5~12000 kg/h

360 t/d

80%

4

4.1

1

2

5

10~20 /t 80%
30~40 /t 80%

4-4

4-4

	720 kcal/kg	100~200 kWh/t
	760 kcal/kg	50~55 kWh/t
	688 kcal/kg	50~80 kWh/t
	688 kcal/kg	50~60 kWh/t
	690 kcal/kg	50~60 kWh/t
	850 kcal/kg	80~100 kWh/t

1

1 pH

pH 12

2

5 ~30

80

74.0 ~48.2

3

4

2

3

3.1

4-6

3.2

1

2

3

4

30 ~50

4

1

30

4-5

4-5

pH

22.7%

	%	30	%		pH
			50		
1	2	28	30.8	33.1	12.5
2	4.6	30	35.9	38.0	12.6
3	6.9	43	39.2	41.4	12.6
4	9	45	48.1		12.6
5	11	58	51.7		12.6
6	14.4	59	54.8		12.6

2

—

5~10d

5

2~4

/t

80%

50~150

70 ~90

1

2

1

2

3

1

N+P₂O₅+K₂O

20 g/kg

200 g/kg

40 g/kg

240 g/kg

30 g/kg

200 g/kg

2

CJ/T309

A

B

A

B

CJ/T 291

3

10 mm

5 mm

0.8 g/cm³

60% 40%

3 ms/cm pH 6.0~8.0

4

60%

50%

75%

5

95%

0.01

4

4.1

4.2

4.3

1

! *f*

4~8 kg/m²

30~40d

2

50%~70%

3

4~8 kg/m²

8~10

kg/m²

4

6~8 kg/m²

5

5~10 kg/m²

12 kg/m²

6

3 kg/m²

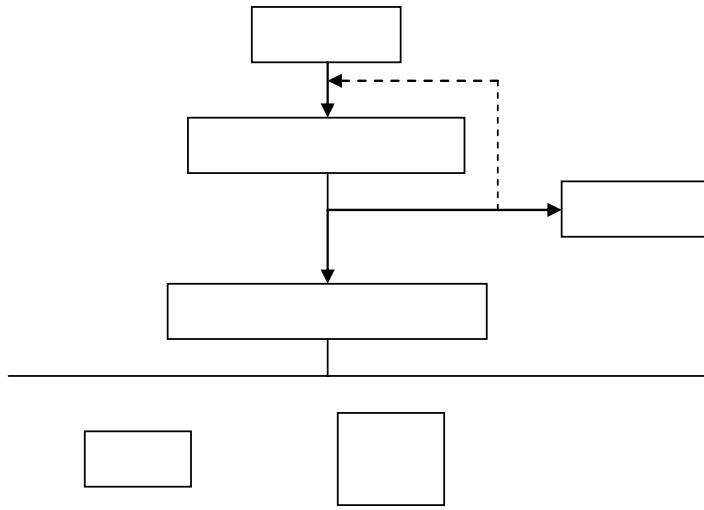

5.2

50 ~60

55 5~7d

5.3

5.4

NaCl

20~40

5.5

1km

5.6

15°

15°

5.7

6
COD

PAHs

5.8

1

1.1

2

S

1

$Q_{ad, net}$ kJ/kg

M_{ar} %

5-1

$$Q_{ar, net} = (Q_{ad, net} + 23M_{ad}) \frac{100 - M_{ar}}{100 - M_{ad}} - 23M_{ar} \quad 5-1$$

$Q_{ar, net}$ ——— M_{ar} % kJ/kg

$Q_{ad, net}$ ——— kJ/kg

M_{ad} ——— %

$M_{ad}=0$

2

5-2

$$A_2 = A_1 \cdot \frac{100 - M_1}{100 - M_2} \quad \dots \quad 5-2$$

A_1 ——— kg/h

M_1 ——— %

A_2 ——— kg/h

M_2 ——— %

3

5-3

$$q_{gh} = (A_1 M_1 / 100 - A_2 M_2 / 100) \cdot \frac{C_v \cdot (T_2 - T_1) + r_{T_2}}{\eta_{gh} / 100}$$

q_{gh} ——— kJ/h

C_v ——— 4.187 kJ/ kg

T_1 ——— 20

T_2 ——— 100

r_{T_2} ——— T_2 2261 kJ/kg

η_{gh} ——— %

4

5-4

$$q_{gl} = A_2 \cdot Q_{2,ar,net} \cdot \eta_{gl} / 100$$

5-4

q_{gl} —

kJ/h

A_2 —

kg/h

$Q_{2,ar,net}$ —

kJ/kg

η_{gl} —

%

$q_{gl} <$

$q_{gl} >$

q_{gh}

q_{gh}

q_{gh}

q_{gl}

kJ/h

80%

40%

85%

13510 kJ/kg

3227

kcal/kg

5

CJ/T 290

1

NO_x SO₂

2.2

2.3

2.4

60%~85%

1

3

2

4

80%

40%

3.4

1

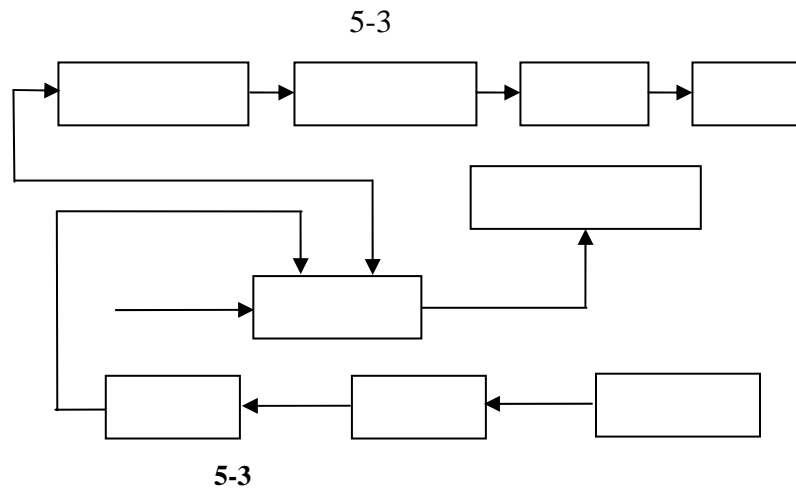

2

850

3.5

1

5-4

5-4

2

40%

850

3.6

40%

3

GB 5085

4

GB 8978

5

GB 3096

GB 12348

GBJ 87

3.7

4.2

4.3

1

5-5

2

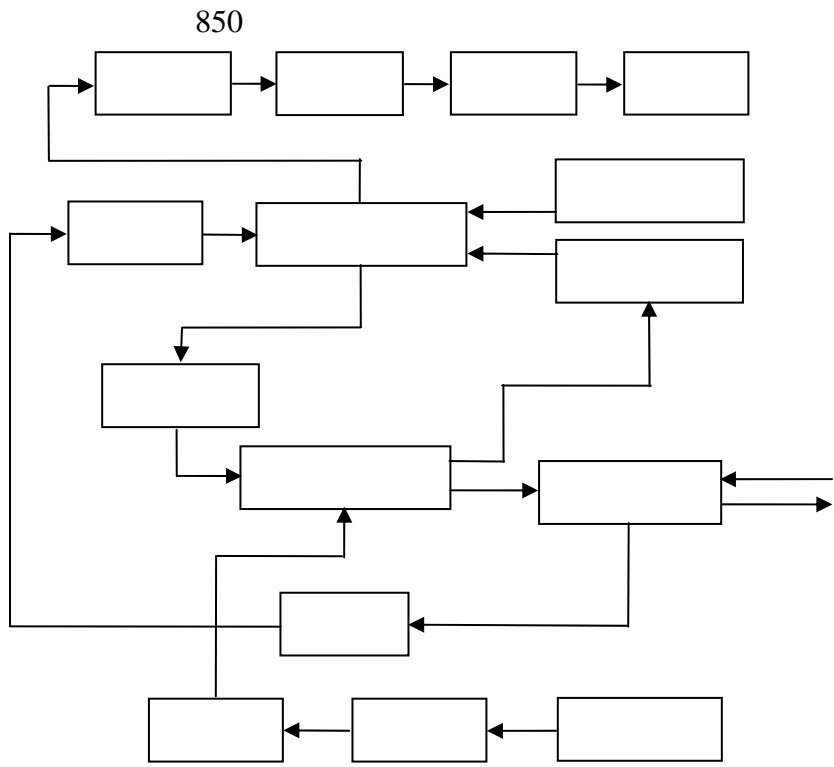

5-5

4.4

1

GB

14554

2

GB 18485

3

GB 18485

4

GB

8978

5

GB 3096

GB 12348

GBJ 87

4.5

10~15 / t

80%

30~40 / t

80%

100~180 / t

80%

55~60kWh/t

80%

	ug/L		
Cu	50	100	300
Zn	50	100	300
Ni	4	50	200

5-3

	3	2
	1	0.5
	5	
	5	
SO ₃	1.0	
		GB/T 17431.2
		19.6.3
%	0.02	
	GB6566	

1.3

1

5-4

5-4

	SiO ₂	Al ₂ O ₃	Fe ₂ O ₃	CaO+MgO	K ₂ O+Na ₂ O
	48~79	8~25	3~12	1~12	0.5~7

$$F_{23} = \frac{SiO_2}{Al_2O_3} \quad \frac{2}{2}$$

3

80%

80%

30%

1100 ~1200

1.4

GB 18485

1.5

30

250~300 /m³

5%~10%

1100

3

Ý . 20 @

1.5

†

4d

2

2.1

GB/T 23485

GB 16889

2.2

1.0 kg/m³

20~30 cm

1.0×10⁻⁷ cm/s

20~30 cm

20~30 cm

20 cm

80 cm

5%

CJJ 17

3

3.1

GB/T 23485

GB 16889

5-5

1

1

2

5~7 d

5

6

2.2

1

0.5m

2

3

4

5

6

5

1

1.1

1

2

3

180

1.2

1

60

2

3

“ ”

GB 50016

2

2.1

3

100 m
300 m
300 m

1
2
3
4
5
6
7
8
9
10
11
12
13
14
15
16
17
18
19
20
21
22
23
24
25
26
27

CJJ 27
GB 50014
AQ 3028
GB 50058
GB 50160
GB 7959
GBZ1
GBZ2
GB 14554
GB 8978
GB 3096
GB 12348
GB 16889
CJJ 17
GB 18918
[2001]101
GB 18485
GB 5085
GB 4915
GB 18484
2000/76/EC
GB/T 17431.1
GB 5101
GB 13544
GB 13545

28 CJJ/T 80
29 CJ/T 3073
30 GB 18598
31
32
33
34 GB 5750
35 HJ/T 164
36 GB 15618
37 HJ/T 166
38 GB 2893
39 GB 2894
40 GB 13223
41 CJ 3082
42 GB24188
43 GB/T 23486
44 GB/T 23485
45 GB24602
46 GB24600
47 CJ/T289
48 CJ/T309
49 GB 50016
50 GB/T23484

